

Volere

Partial Example Requirements Specification

For

Library Loans Ltd.

Library Loans

*This **partial** example is intended for users of the Volere Requirements Template. The example illustrates how you could use Volere to specify the requirements for a product that controls library loans.*

by James & Suzanne Robertson
principals of the Atlantic Systems Guild

The Volere Requirements Specification Template is intended for use as a basis for your requirements specifications. The template provides sections for each of the requirements types appropriate to today's software systems. You may download the template from the Volere site and adapt it to your requirements gathering process and requirements tool. The template can be used with Requisite, DOORS, Caliber RM, IRqA and other popular tools see <http://www.volere.co.uk/tools.htm>

The template may not be sold, or used for commercial gain or purposes other as a basis for a requirements specification without prior written permission. Details of the usage fee are on the Volere site. The Template may be modified or copied and used for your requirements work, provided you include the following copyright notice in any document that uses any part of this template:

We acknowledge that this document uses material from the Volere Requirements Specification Template, copyright © 1995 – 2012 the Atlantic Systems Guild Limited.

Contents

Project Drivers

1. The Purpose of the Project
2. The Stakeholders

Project Constraints

3. Mandated Constraints
4. Naming Conventions and Terminology
5. Relevant Facts and Assumptions

Functional Requirements

6. The Scope of the Work
7. Business Data Model & Data Dictionary
8. The Scope of the Product
9. Functional Requirements

Nonfunctional Requirements

10. Look and Feel Requirements
11. Usability and Humanity Requirements
12. Performance Requirements
13. Operational and Environmental Requirements
14. Maintainability and Support Requirements
15. Security Requirements
16. Cultural and Political Requirements
17. Legal Requirements

Project Issues

18. Open Issues
19. Off-the-Shelf Solutions
20. New Problems
21. Tasks
22. Migration to the New Product
23. Risks
24. Costs
25. User Documentation and Training
26. Waiting Room
27. Ideas for Solutions

Volere

Volere is the result of many years of practice, consulting, and research in requirements engineering and business analysis. We have packaged our experience in the form of a generic requirements process, requirements training, requirements consultancy, requirements audits, a variety of downloadable guides and articles, and this requirements template. We also provide requirements specification-writing services.

The first edition of the Volere Requirements Specification Template was released in 1995. Since then, organizations from all over the world have saved time and money by using the template as the basis for discovering, organizing, and communicating their requirements.

The Volere web site www.volere.co.uk contains articles about the Volere techniques, experiences of Volere users and case studies, requirements tools, and other information useful to requirements practitioners.

The Volere requirements process is described in the book *MASTERING THE REQUIREMENTS PROCESS—SECOND EDITION* by Suzanne Robertson and James Robertson, Addison-Wesley, 2006. ISBN 0-321-41949-9

FOR MORE ABOUT MANAGING REQUIREMENTS SEE *REQUIREMENTS LED PROJECT MANAGEMENT* by Suzanne Robertson and James Robertson, Addison-Wesley, 2005. ISBN 0-321-65904-X

Updates to this template and instructions for downloading are available at <http://www.volere.co.uk>

Public seminars on Volere are run on a regular basis in Europe, the United States, Australia, and New Zealand. For a schedule of courses, refer to www.volere.co.uk.

1. The Purpose of the Project

1a. The User Business or Background of the Project Effort

The clients of Library Loans Ltd. are public and university libraries all over the world. Feedback from clients is that they have a high incidence of late returns of library book loans. Some books are never returned. We have decided to invest in this project because our market research indicates that the new functionality will be taken up by a majority of our customers. Also potential new customers will be influenced to buy our software rather than that of our competitors. The changes to the software will help the libraries to minimize the late/non return of library loans. This project will produce a new version of our existing Library Management product.

1b. Goals of the Project

1b.1

Purpose:

To provide functionality to control the late/non return of library loans.

Advantage:

To avoid losses due to late or non return of books.

Measure:

At any time the library will know how many loans are outstanding and when they need to follow them up in order to avoid them turning into overdue loans.

1b.2

Purpose:

We want to sell the new functionality to our existing customers.

Advantage:

To retain our customer base.

Measure:

80% of our existing customer base will buy the new library loans software within 12 months of its release.

1b.3

Purpose:

We want to increase our customer base.

Advantage:

To be the number 1 supplier of library software worldwide.

Measure:

30% increase in the number of customers and revenue in our customer base within 2 years of its release. Refer to the sales projection graph SP2012.

2. The Client, the Customer, and Other Stakeholders

2a. The Client

Amy Dewey, the chief executive officer of Library Loans Ltd.

2b. The Customer

Public and private libraries in the United Kingdom

Libraries overseas

University libraries

2c. Other Stakeholders

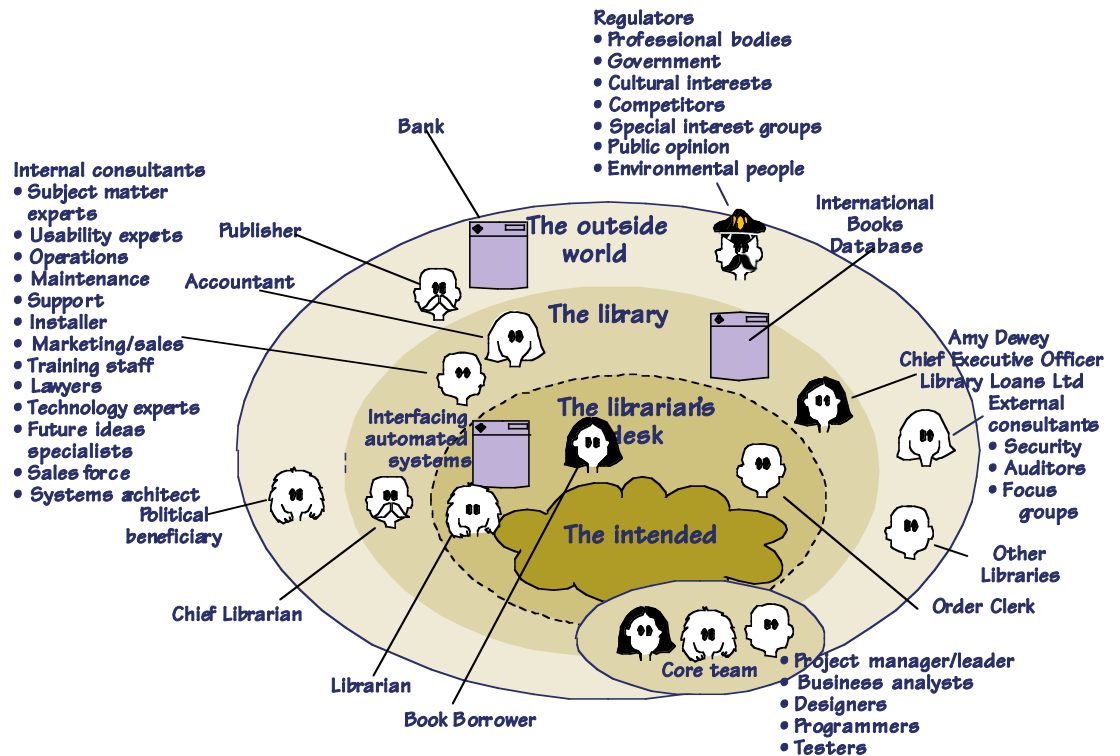

The roles and (if possible) names of other people and organizations who are affected by the product, or whose input is needed to build the product.

For each type of stakeholder, provide the following information:

- Stakeholder identification (some combination of role/job title, person name, and organization name)
- Knowledge stakeholder will contribute to the project
- The degree of involvement necessary for that stakeholder/knowledge combination
- The degree of influence for that stakeholder/knowledge combination
- Agreement on how to address conflicts between stakeholders who have an interest in the same knowledge

2d. The Hands-On Users of the Product

User Categories:

- Librarians
- Adult book borrowers
- Child book borrowers
- Other user characteristics: for each of the user categories above we will define the following characteristics. We will use these characteristics to guide us in defining the most appropriate functional and non-functional requirements.

Physical abilities/disabilities

Intellectual abilities/disabilities

Attitude toward job

Attitude toward technology

Education

Linguistic skills

Age group

Gender

3. Mandated Constraints

3a. Solution Constraints

Description: The library loan system shall have an interface to the International Books Database

Rationale: This is the central source of information about books

Fit criterion: the interface with the International Books Database shall conform to Interface Specification Standard IBD2

3b. Implementation Environment of the Current System

3c. Partner or Collaborative Applications

3d. Off-the-Shelf Software

3e. Anticipated Workplace Environment

3f. Schedule Constraints

Description: The product shall be available by January 1, 2013

Rationale: We want to launch the product at the International library conference

Fit criterion: The library loan system shall be available for sale to libraries by January 1, 2013

3g. Budget Constraints

The project budget is 2.5 million Euros

4a. Glossary of All Terms, Including Acronyms, used in the Project

A glossary containing the meanings of all names, acronyms, and abbreviations used within the requirements specification. This acts as a starting point for the data dictionary definitions in Section 7. The following is an incomplete example.

Partial Glossary of naming conventions for Library Loans Project

Name	Description
Book	A publication available for loan
Book ISBN	Unique identifier for a book
Book Loan Agreement	Agreement between Book Borrower and Library
Borrower	Person or organization who borrows books from a library
Borrower Id	Unique number assigned by the library
Borrower Name	Name by which the borrower is known
Chosen Book	Book that borrower has chosen to borrow
Finance Department	The finance department of the library
International Books Database (IBD)	A database containing details of all published books. This is maintained by the International Library association.
Library	A library belonging to the International Library Association
Library Id	Unique number assigned by the International Library Association
Loan	Record of the loan of a book
Loan Extension Approval	Decision made by library to approve extension of a loan
Loan Extension Request	Request from borrower to extend an existing loan
Loan Expiry Date	The date that a loaned book must be returned
Loan Start Date	The date that a book loan starts
New Book Availability	Alert from publisher re availability of new book
New Book Delivery	A new book delivered by the publisher in response to an order
New Book Details	Book details provided by the international books database
New Book Enquiry	Enquiry sent to the international books database

New Book Order	A book order from a library to a publisher
New Book Payment Confirmation	Informs publisher that payment has been made
Publisher	An organisation that publishes books
Refused Loan Extension	Decision made by library to refuse extension of a loan

5. Relevant Facts and Assumptions

5a. Facts

Research shows that 5% of library loans are extended with permission and another 30% are returned late without arranging an extension.

5b. Assumptions

A specification of the upgrade to the International Books Database is not available. We are proceeding on the basis that the upgrade to the International Books Database will not affect the specification of the interface IBD2. Any change to this interface will necessitate a reassessment of functionality, time and costs for the Library Loans Project.

6. The Scope of the Work

6a. The Current Situation

The work of library loans is currently carried out with a mixture of file cards, Exel spreadsheets, Access databases, manual procedures and some custom built pieces of software including the Library Management System marketed by Library Loans Ltd. See the attached library *business process models* for details on the “how now” situation of how the work is carried out.

6b. The Context of the Work

This model identifies the boundary of the investigation that is necessary in order to understand the business of managing library loans and to specify the business requirements. Note that each input and output interface on the model will be defined in detail in the Data Dictionary – Section 7.

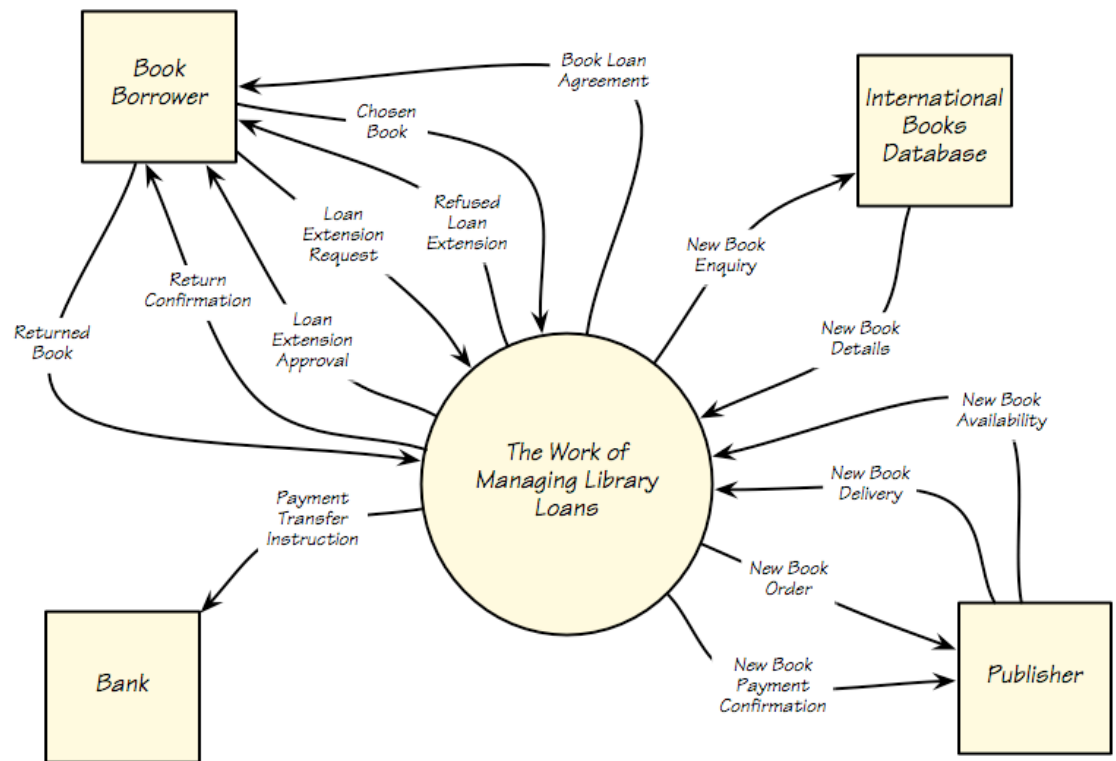

6c. Work Partitioning

The following Business Event List is the result of using business events to partition the Work of Managing Library Loans into five business functions. Note that, via its input and output, each of the business events can be traced back to the higher level summary of the context of the work of managing library loans. Note also that each of the inputs and outputs is defined in the dictionary in section 5.

BUSINESS EVENT LIST

No.	Event Name	Input	Output
1	Borrower chooses book	- Chosen Book	- Book Loan Agreement
2	Borrower wants to extend loan	- Loan Extension Request	- Loan Extension Approval - Refused Loan Extension
3	Publisher has new book available	- New Book Availability	- New Book Order
4	Publisher delivers new book	- New Book Delivery	- New Book Enquiry

		- New Book Details	
5	Time to pay for new books	- <i>None</i>	- Payment Transfer Instruction - New Book Payment Confirmation
6	Borrower returns book	- Returned Book	- Return Confirmation

6d. Business Use Case (BUC) scenarios

BUC Scenario for Business Event 2: Borrower wants to extend loan

Business Event 2: Borrower wants to extend loan

Business Use Case: Decide on loan extension

Trigger: Loan Extension Request

Preconditions: The Borrower must have an existing loan for the book in question

Interested Stakeholders: Chief Librarian, Other Libraries, Auditors

Active Stakeholders: Duty Librarian, Borrower

- The Borrower gives the *Loan Extension Request* to the duty librarian.
- The librarian finds the book loan agreement for the requested extension.
- The librarian finds any other books that are currently loaned to the borrower.
- If the due return date on each of the books is later than today's date

then

the librarian tells the borrower there is a *loan extension approval*

the librarian records the loan extension

otherwise

the librarian tells the borrower there is a *refused loan extension*

the librarian records the refused extension

the librarian asks the borrower to return the overdue books

Outcome: The decision on book loan extension is made and the borrower is informed.

6e. Annotated Business Use Case (BUC) scenarios

The following is an example of using a BUC Scenario as the input for exploring how a product could improve this BUC. Note that there could be many versions of the annotated BUC; it is intended as a vehicle for exploring preliminary design ideas and for questioning the current business rules.

Annotated BUC Scenario for Business Event 2: Borrower wants to extend loan

Business Event 2: Borrower wants to extend loan

Business Use Case: Decide on loan extension

Trigger: Loan Extension Request

Preconditions: The Borrower must have an existing loan for the book in question

Interested Stakeholders: Chief Librarian, Other Libraries, Auditors

Active Stakeholders: Duty Librarian, Borrower

- The Borrower gives the *Loan Extension Request* to the duty librarian. *The librarian enters the Borrower's Id.*
- The librarian finds the book loan agreement for the requested extension.
- The librarian finds any other books that are currently loaned to the borrower.

The product can interact directly with the borrower.

The product finds all the books currently on loan to the borrower.

The product flags loans that are overdue.

- If the due return date on each of the books is later than today's date
then

the librarian tells the borrower there is a *loan extension approval*

the librarian records the loan extension

otherwise

the librarian tells the borrower there is a *Refused Loan Extension*

the librarian records the refused extension

the librarian asks the borrower to return the overdue books

The librarian has the power to override a *Refused Loan Extension*

Outcome: The decision on book loan extension is made and the borrower is informed.

7a. Data Model

The business data model identifies the classes (rectangles) of business data and the relationships (lines) between them. The cardinality is represented by * (many) and 1 (one). This data model uses UML class model notation – there are many other alternative notations. The attributes of each class are defined in the data dictionary (see 7b).

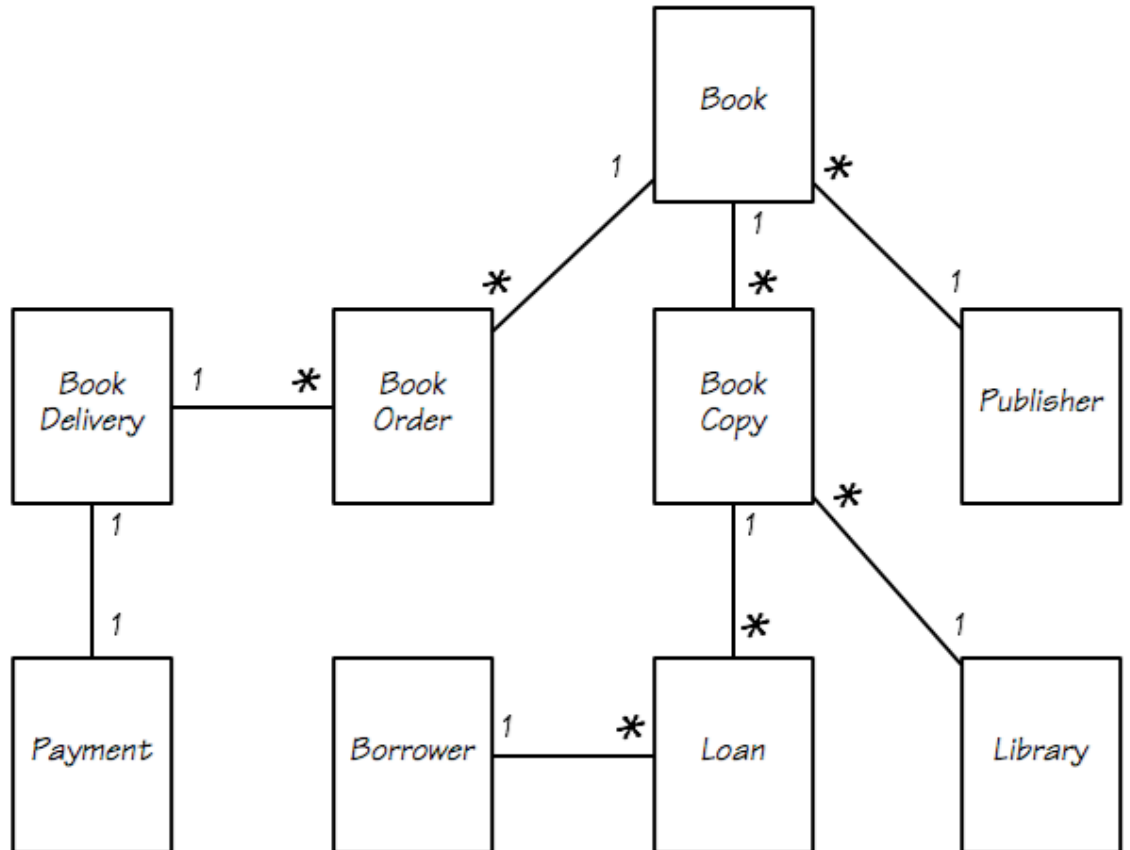

7b. Data Dictionary

A dictionary containing the meanings of all names, acronyms, and abbreviations used within the requirements specification. The following is an incomplete example.

Data Dictionary containing naming conventions and definitions for Library Loans

Data Name	Description	Definition	Data Type
Author	The writer of a book	Author Name	Class
Author Name	Name of the writer of a book		Data Element
Bank Account Transfer Details	A publisher's bank details for transferring payments		Data Element

Book	A publication available for loan	Book ISBN + Book Title + Published Date + Book Classification	Class
Book Copy	A specific copy of a book	Copy Number	Data Element
Book Classification		[Fiction Non-Fiction Children]	Data Element
Book Delivery	Data stored to keep track of deliveries of ordered books	Delivery Reference + Delivery Date + Number of Copies Delivered + Delivery Price	Class
Book ISBN	Unique identifier for a book	Identifier assigned by central body	Data Element
Book Loan Agreement	Agreement between Book Borrower and Library	Borrower Name + Borrower Id + Library Id + Book ISBN + Copy Number + Loan Start Date + Loan Expiry Date	Dataflow
Book Order	Data stored to keep track of a New Book Order	Order Number + Order Date + Number of Copies	Class
Book Title	Title of a book supplied by the publisher		Data Element
Borrower	Person or organization who borrows books from a library	Borrower Name + Borrower Id + Borrower Address	Class
Borrower Id	Unique number assigned by the library	Number from 1 to 10000000	Data Element
Borrower Name	Name by which the borrower is known	Borrower Title + Borrower Forename + Borrower Surname	Data Group
Copy Number	Number to identify multiple copies of books with the same ISBN		Data Element
Chosen Book	Book that borrower has chosen to borrow	Borrower Id + Book ISBN + Copy Number + Book Title	Dataflow
Delivery Price	The price charged to the Library by the publisher for the supply and delivery of ordered books		Data Element
Finance Department	The finance department of the library	Finance Department Contact	Adjacent System Stakeholder
International Books Database	A database containing details of all published books. This is maintained by the International Library	{Book ISBN + Book Title + Author Name + Published Date + Book Classification}	Database External

	association.		
Library	A library belonging to the International Library Association	Library Id + Library Address	Class
Library Id	Unique number assigned by the International Library Association	Structure defined in Library Id definition document LID2008	Data Element
Loan	Record of the loan of a book	Loan Start Date + Loan Expiry Date + Return Date + (Loan Extension Date)	Class
Loan Extension Approval	Decision made by library to approve extension of a loan	Library Id + Borrower Id + Book ISBN + Copy Number + Loan Extension Date	Dataflow
Loan Extension Date	Extension to the date by which a book must be returned		Data Element
Loan Extension Request	Request from borrower to extend an existing loan	Borrower Id + Book ISBN + Book Title + Extension Request Date	Dataflow
Loan Expiry Date	The date that a loaned book must be returned		Data Element
Loan Start Date	The date that a book loan starts		Data Element
New Book Availability	Alert from publisher re availability of new book	Book ISBN + Book Title + Author Name + Book Review + Publisher Name + Published Date + Book Price	Dataflow
New Book Delivery	A new book delivered by the publisher in response to an order	Book ISBN + Book Title + Order Number + Delivery Date + Delivery Price + {Physical Book}	Dataflow
New Book Details	Book details provided by the international books database	Book ISBN + Book Title + Author Name + Publisher Name + Published Date + Book Price	Dataflow
New Book Enquiry	Enquiry sent to the international books database	Book ISBN + Book Title + Author Name	Dataflow

New Book Order	A book order from a library to a publisher	Book ISBN + Book Title + Publisher Name + Number of Copies + Order Number + Order Date	Dataflow
New Book Payment Confirmation	Confirmation of payment to a publisher for a new book	Publisher Id + Book ISBN + Payment Amount + Payment Date + Bank Account Transfer Details	Dataflow
Order Number	A library's reference for a book order made to a publisher		Data Element
Payment	Record of payment made for a book delivery	Payment Date + Payment Amount	Class
Physical Book	A physical copy of a book		Material
Published Date	The date a book is available for sale		Data Element
Publisher	An organisation that publishes books	Publisher Id + Publisher Name + Publisher Address + Bank Account Transfer Details	Class and Adjacent System
Refused Loan Extension	Decision made by library to refuse extension of a loan	Library Id + Borrower Id + Book ISBN + Copy Number + Extension Refusal Reason	Dataflow
Return Confirmation	Confirmation that borrower has returned a book	Borrower-Id + Book ISBN + Copy Number + Return Date	Dataflow
Return Date	Date that borrower returns a book to the library		Data Element
Returned Book	Book returned to library	Library Id + Borrower Id + Book ISBN + Copy Number + Return Date + Physical Book	Dataflow

8. The Scope of the Product

8a. Product Boundary

The product scope diagram identifies the boundaries between the users (actors) and the product. This diagram is a summary of all of the product use cases (PUCs). You arrive at the product boundary by inspecting each business use case and determining, in conjunction with the appropriate

stakeholders, which part of the business use case should be automated (or satisfied by some sort of product) and what part should be done by the user. This task must take into account the abilities of the actors (section 2d), the constraints (section 3), the goals of the project (section 1), and your knowledge of both the work and the technology that can make the best contribution to the work.

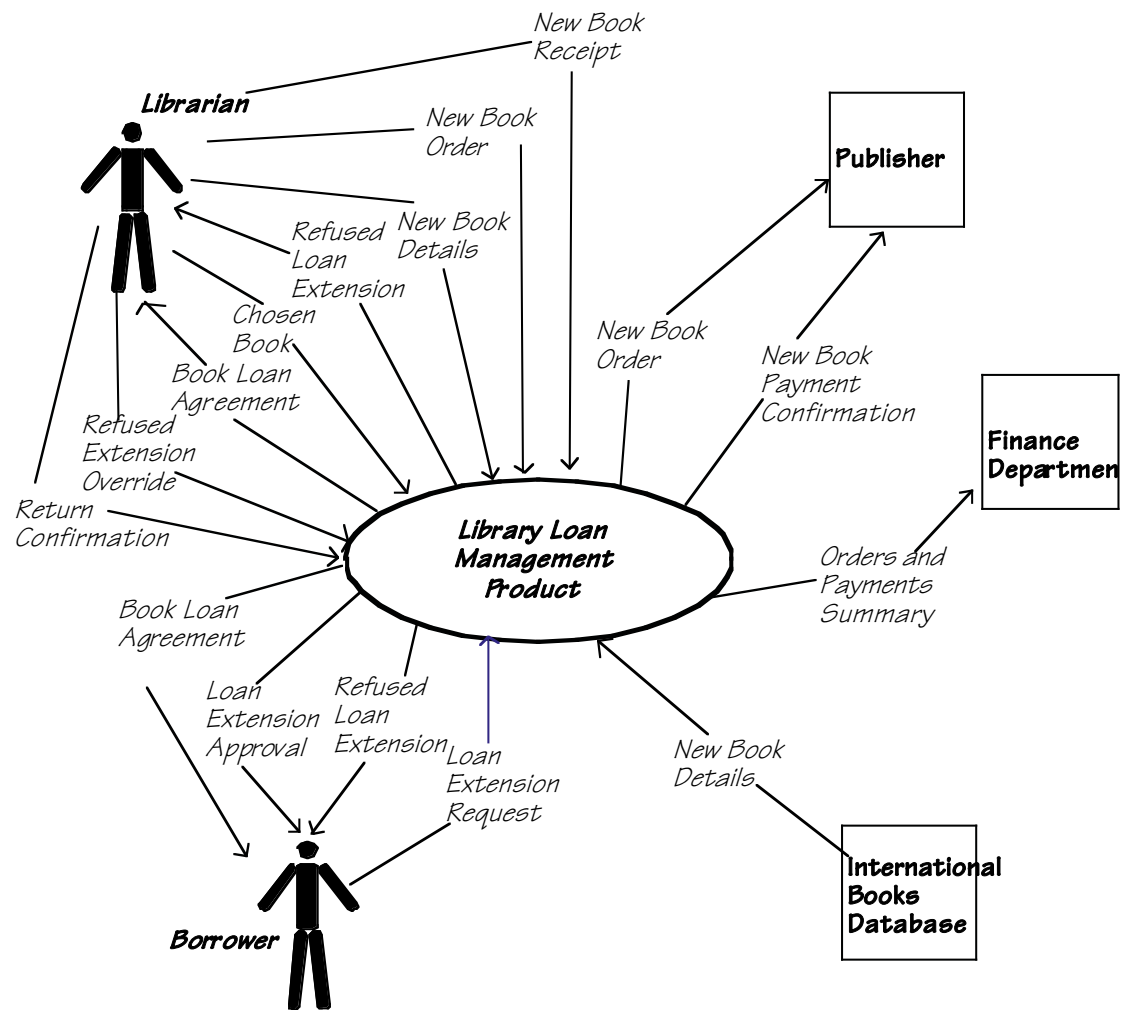

8b. Product Use Case Table

The product scope diagram is a graphical way of summarizing the product boundary. The product use cases are inside the boundary, identified by the ellipse. You can make a list of the product use cases and, just as you made the business use cases traceable back to the work context, you make the product use cases traceable to the product scope.

Product Use Case (PUC) Summary Table

BUC No	PUC No	PUC Name	Actor/s	Input & Output
1	1	Make Book Loan Agreement	Librarian, Borrower	Chosen Book (in) Book Loan Agreement (out)
2	2.1	Determine Extension Eligibility	Borrower, Librarian	Loan Extension Request (in) Loan Extension Approval/Refused Loan Extension (out)
2	2.2	Override Refused Extension	Borrower, Librarian	Refused Extension Override (in) Loan Extension Approval (out)
3	3.1	Communicate New Book Details	International Books Database, Librarian	New Book Details (in) New Book Details (out)
3	3.2	Order New Book	Librarian, Publisher	New Book Order (in) New Book Order (out)
4	4	Add New Book to Library	Librarian	New Book Receipt (in)
5	5.1	Pay For Books	Publisher	New Book Payment (out)
5	5.2	Summarise Orders and Payments	Finance Department	Orders and Payments Summary (out)
6	6.1	Record returned book	Librarian	Return Confirmation (in)

8c. Individual Product Use Cases

A product use case (PUC) is part of the BUC that will be carried out by the product. There can, and often will, be several PUCs related to one BUC. This is where you keep details about the individual product use cases on your list. You can include a scenario for each product use case on your list.

The following example shows the Product Use Cases (PUC's) derived from BUC 2 – Borrower wants to extend loan:

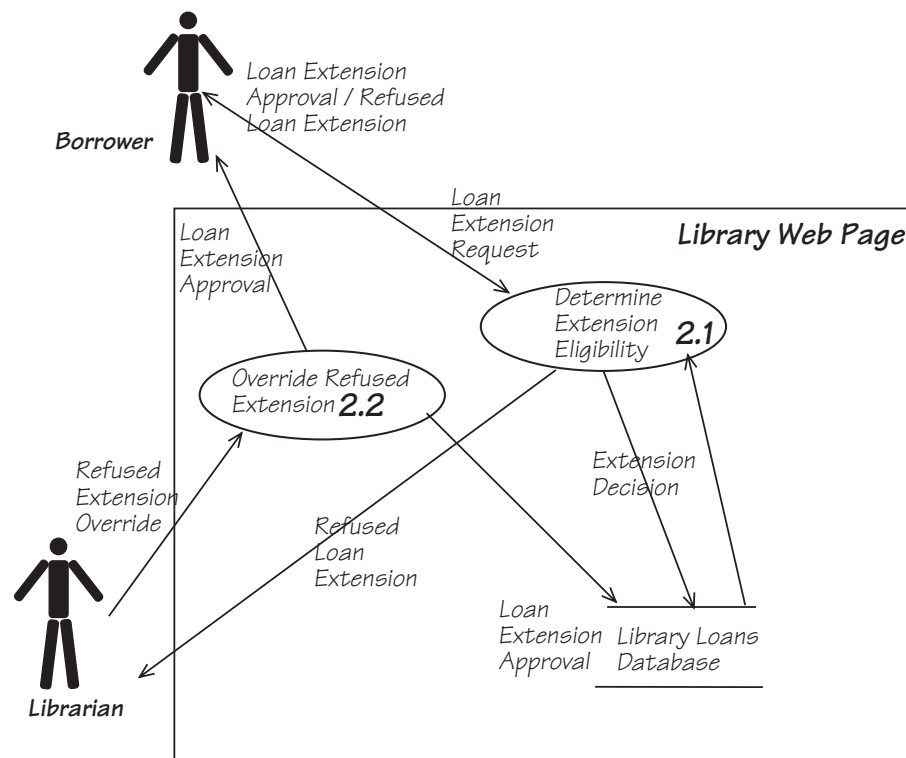

8d. Product Use Case Scenarios

The following is an example of a scenario for one of the PUC's derived from the ideas in the annotated BUC 2 scenario.

PUC 2.1 Determine Extension Eligibility - Traceable back to BUC 2

Accept the *Loan Extension Request* from the *Borrower*

Find all the books currently on loan to the *Borrower*

If any of the books are overdue

Then

give the *Borrower* a *Refused Loan Extension*

give the *Librarian* a *Refused Loan Extension*
 Otherwise (none of the Borrower's loans are overdue)
 give the *Borrower* a *Loan Extension Approval*
 Update *Loan Expiry Date* with the *Extension Request Date*

Record the *Extension Decision*

9-17. Functional and Non-functional ;Requirements

The following is an example of the Functional and Non-functional atomic requirements related to PUC 2.1.

PUC Number	PUC Name	BUC Number
2.1 (see PUC scenario 2.1)	Determine Extension Eligibility	2 (see BUC scenario 2)

Reqt #	Reqt Type	Description	Rationale	Fit Criterion	Other Related PUCs
0001	Functional	The product shall accept a <i>Loan Extension Request</i> for the <i>Borrower</i>	Need to know which book loan the borrower wishes to extend	See definitions of <i>Loan Extension Request</i> , <i>Borrower</i> in Terms and Definitions	PUC 2.2
0002	Functional	The product shall find outstanding book loans	Need to know which books are past the loan expiry date	An Outstanding Book Loan is one where the <i>Loan Expiry Date</i> is before Today's Date	PUC 2.2
0003	Functional	The product shall inform the borrower if the loan extension has been refused along with the reason for refusal	To keep the Borrower informed	See definitions of <i>Refused Loan Extension</i> , <i>Borrower</i> in Terms and Definitions	PUC 2.2
0004	Functional	The product shall inform the librarian if the loan extension has been refused along with the reason for refusal	To keep the Librarian informed	See definitions of <i>Refused Loan Extension</i> , <i>Librarian</i> in Terms and Definitions	PUC 2.2

0005	Functional	The product shall record that the extension has been refused	To keep a record that the borrower has been informed	See definitions of <i>Refused Loan Extension</i> in Terms and Definitions	PUC 2.2
0006	Functional	The product shall record the new loan expiry date	To keep track of extended loans	the new <i>Loan Expiry Date</i> is the <i>Extension Request Date</i>	PUC 2.2
0007	Functional	The product shall inform the buyer if the loan extension has been approved	To keep the Borrower informed	See definitions of <i>Loan Extension Approval</i> , <i>Borrower</i> in the Terms and Definitions	PUC 2.2
0008	Look and Feel	The product shall be recognisable as a product belonging to the specific library	To promote the image of the library to the borrower	Borrowers are able to recognise the product as belonging to their Library the first time they use it.	All other PUC's with a direct interface to the Borrower
0009	Usability	The product shall make it easy for the Borrower to enter his identification and details of the loan that he wants to extend	To avoid annoying the Borrower and wasting his time.	The Borrower can tell the product his Borrower Id, Book Title, requested Extension Date within n secs without any training or need to consult instructions.	
0010	Performance	The product shall communicate the decision quickly.	To avoid annoying the Borrower	The product communicates the loan extension decision within n secs of the Borrower communicating the Borrower Id, Book Title, requested Extension Date	
0011	Operational	The product shall run on the most popular Internet browsers.	To be compatible with the variations between libraries.	All product's functions allocated to the internet must work as specified using all the	All other PUC's with functionality that is allocated to the internet.

				browsers specified in the Library Ltd Browser compatibility list version 5.	
0012	Maintainability	The product shall be able to add new loan extension rules.	Libraries sometimes change their extension rules	Changes in the loan extension rules will be implemented within 7 working days provided the scope of the product is not changed. For a definition of product scope, refer to section 8 plus Naming conventions and definitions.	PUC 2.2
0013	Security	The product shall only allow the authorised Borrower to view his library loans.	To confirm with privacy rules.	Any access of the library loans is proved to be made by the authorised borrower or an authorised librarian.	
0014	Cultural	The product shall be usable by Borrowers who do not speak English.	Libraries loan many non-english books to non-english borrowers.	A representative sample of Borrowers who do not speak English are able to extend a library loan within n minutes of encountering the product.	
0015	Legal	The product shall apply the same loan extension rules to all borrowers.	To protect the borrowers' legal rights	All loan extension decisions shall be consistent depending on Borrowers' library loan history.	PUC 2.2